

MultiPure

FILTRATION OF LARGE FLUID VOLUMES

Filtration of large volume fluid reservoirs
Hydraulic fluid is a crucial component of hydraulic systems. Contamination of this fluid is the main cause of hydraulic system failures. Filtration of hydraulic fluids is the solution, but can be a complicated process, especially for large volume reservoirs.

The MultiPure

RMF Systems specially designed the MultiPure for the filtration of hydraulic fluids in large reservoirs. The filtration unit comes as a one skid design, it combines 12 highly efficient Cellulose filter elements (60 HB) in a carbon steel housing. The robust steel pump with integrated safety guarantees a stable flow of the oil through the filter elements. The electric motor is compatible with most common electrical grids. The MultiPure is suitable for almost any industry and has an electric motor that is compatible with most common electrical grids.

Removal of small particle contamination

Most standard fitted system filters contain fibreglass filter elements and do not remove particles smaller than 3 micron. These smaller particles quickly develop in hydraulic applications with high pressures. Cluttering of these small particles can result in the development of varnish, an increase of the TAN value of the oil and significantly reduces the lubrication quality of the oil. Causing server damage to your system.

Highly efficient Radial Micro Filtration

RMF Systems applies Radial Micro Filtration. The filter elements in our MultiPure consist of over 200 layers of Cellulose, and are especially designed to remove even the smallest particles under low flow and pressure circumstances. By removing particles as small as this, the oil will stay much cleaner, the TAN value of the oil will remain low and the oil will also keep its lubrication characteristics. The MultiPure will significantly prolong the service life of your oil. This extension can save you considerably, especially when you use large amounts of hydraulic fluids.



The MultiPure

Benefits

- 1 Removes even the smallest contamination particles
- 2 Prevents high TAN values
- 3 Significantly prolongs service life of fluid and system
- 4 Reduces downtime and maintenance costs
- 5 Reduces cost of ownership



Steel Industry

Paper Industry

Turbines

Oxidation

The filter elements in the MultiPure also remove dissolved water from the hydraulic fluid. Removing both water and metal particles will significantly stabilize oxidation of the fluid. The result will be an extended service life of both fluid and system components, less downtime and maintenance and therefore lower costs of ownership.

Plug & play operation

The MultiPure can be equipped with a control box for easy plug & play operation. The control box consists of a main power switch, on/off switch, emergency stop and filter clogged warning and alarm lights. An additional USB connection on the bottom of the unit makes it possible to connect your computer for the exchange of data.

Condition Monitoring

A Condition Monitoring Center can be additionally integrated. The Condition Monitoring Center can be outfitted with various sensors; a particle counter, an oil degradation sensor and a water sensor. All sensors provide real time information on the condition of your fluid. Data storage, included free software and USB connectivity make monitoring your fluid condition and data collection easy. With the Condition Monitoring Center you can base the maintenance of your system on the actual condition of the fluid instead of performing unnecessary maintenance based just on elapsed time.



MultiPure

TECHNICAL SPECIFICATIONS & DIMENSIONS

Weight	±800 kg
Nominal flow	50 l/min
Maximum viscosity @ nominal flow rate	180 cSt ($\Delta p=6,0$ bar)
Max operating pressure	16 bar
Pump safety valve	15 bar
Bypass valve	6 bar
Filter elements	60HB
Element seals	NBR (Buna-N)
Maximum oil temperature	80° C (contact RMF Systems for other temperatures)
Inlet connection	1 1/2" SAE 3000 PSI (metric)
Outlet connection	G 1 1/4" BSPP
Power Supply	230/400 VAC 50Hz / 3 Phase 255/460 VAC 60Hz / 3 Phase 200/346 VAC 50/60Hz / 3 Phase
Control box	On/off, motor protection relais and 24VDC power supply for CMS and OQS unit. Integrated double RS485 to USB converter for data transfer
Fluid Compatibility	H, HL, HLP, HVLP, HEES (for other fluids, please contact RMF Systems)

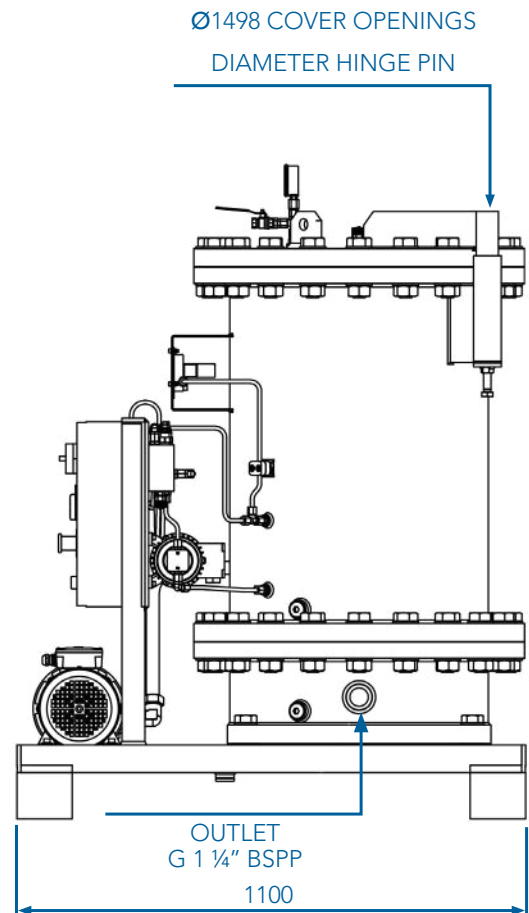
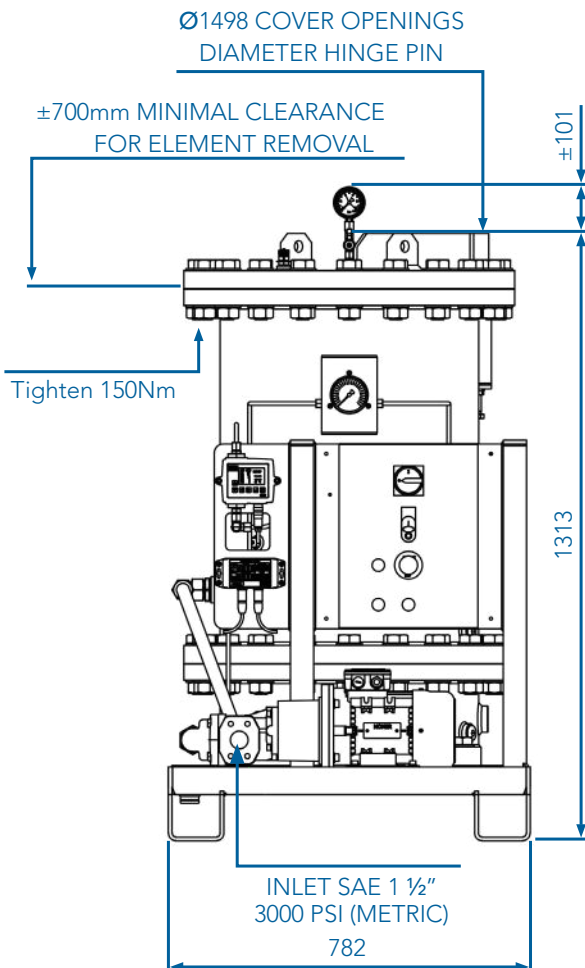

MultiPure

ORDERING CODE

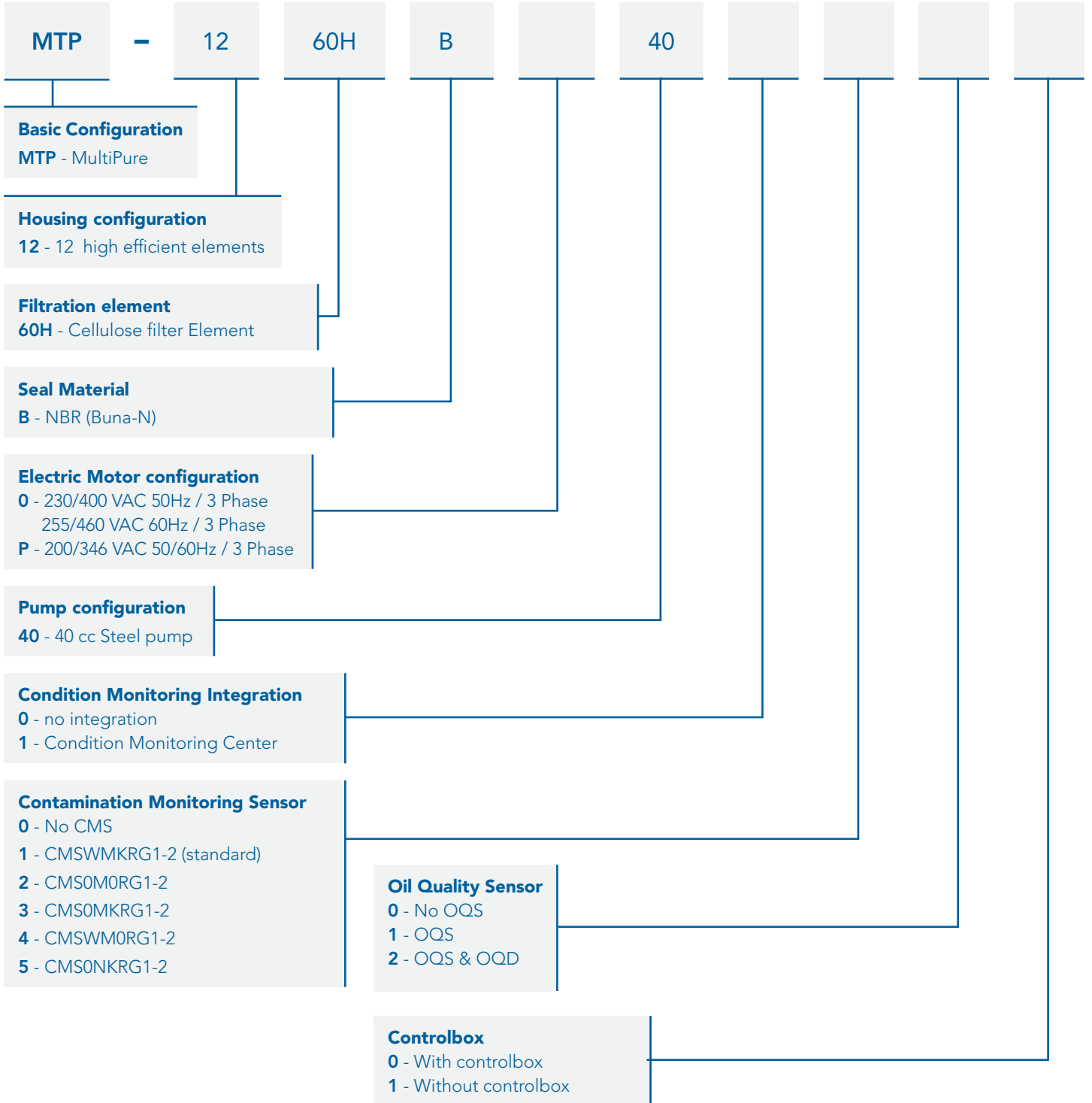

EXAMPLE

MTP - 12 60H B 0 40 1 1 2 1