

BREATHERS:

HydroGuard

Protection from moisture and particulate contamination in low-flow, steady-state operations.



APPLICATIONS:

- Totes
- Transformers
- Storage Tanks
- Hydraulics

The Overview

HydroGuard Breathers: The Highlights

- Expansion chamber and internal check-valve system create a nearly-sealed system
- Eliminates rust-forming condensation
- Prevents sludge deposits and water-contaminated oil
- Provides longer oil and filter life
- Reduces wear and tear on equipment, prolongs life

By the Numbers:

1-Recessed Check-Valves

High-quality umbrella check-valves that won't clog or stick are recessed underneath the unit for added protection from washdown environments. Check-valves isolate equipment from ambient conditions, prolonging breather life.

2-Expansion Chamber

The diaphragm allows for expansion/contraction of the air within the casing as a result of temperature variations during steady-state operations.

3-Integrated Nylon Standpipe

The integrated standpipe provides excellent vibration resistance and dissipates impact throughout the unit, eliminating weak points. It also allows even airflow distribution throughout the unit, eliminating inaccurate readings of desiccant saturation.

4-Resilient Polycarbonate Body

Shock-absorbing, clear casing provides reliable service and easy maintenance.

5-Filter Element

Polyester filter element removes airborne contamination to 3-micron absolute. Unique loops allow particles to release during system exhalation, helping to increase breather life.

6-Water Adsorbent

Silica gel adsorbs water from incoming air and can hold up to 40% of its weight. Condition is indicated by change of color from blue to light pink.

7-Foam Pad

Foam filter captures any oil mist and disperses incoming air evenly over filtration and drying areas.

8-Threaded Mounting

Easily replaces standard filler/breather cap with multi-fit connection or one of several adapters.

How It Works:

As wet, contaminated air is drawn through the unit, multiple 3-micron polyester filter elements remove solid particulate while the color-indicating silica gel extracts moisture.

The diaphragm allows for expansion/contraction of the air within the casing as a result of temperature variations during steady-state operations.

When air is expelled from the container, the top foam pad prevents oil mist from contacting silica gel or entering the atmosphere.

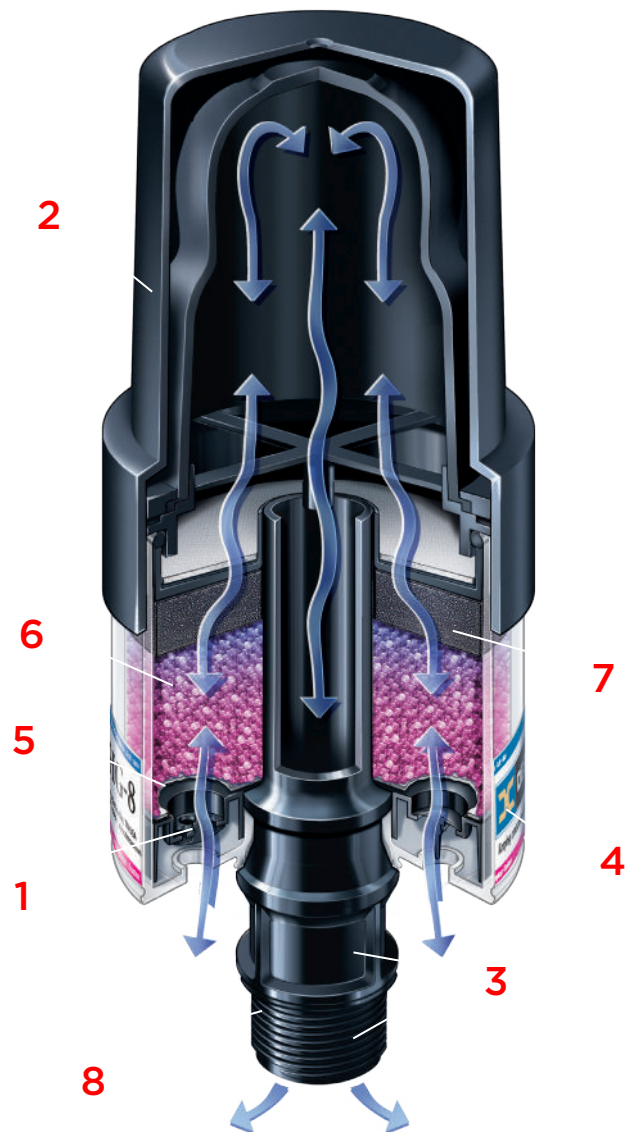

Charts & Graphs

Materials & Components:

	DC-HG-1	DC-HG-8
Unit Height	7.2"/18.3cm	9.8"/24.8cm
Unit Diameter	2.5"/6.4cm	4.1"/10.4cm
Shipping Weight (unit/case)	0.58lbs/3.75lbs 0.26kg/1.7kg	1.81lbs/11lbs 0.82kg/4.92kg
Amount of Desiccant	0.28lbs/125.1g	0.65lbs/0.24g
Max. Adsorption Capacity (fl oz./ml)	1.68 fl. oz. /49.6ml	4.05 fl. oz. /120ml
Max. Air Flow Rate (cfm)	1.41 @ 1psid	2.5 @ 1psid
Max. Fluid Flow Rate (lpm/gpm)	39.93/10.575	70.5/18.75
Filtration	3 μ absolute	3 μ absolute
Operating Temp. Range	-20°F-200°F/ -29°C-93°C	
Hydrophilic Agent	Silica gel	
Filter Media	Polyester	
Connection Size	3/8" Multi-fit (NPT, BSPP, BSPT)	1" Multi-fit (NPT, NPSM, BSPT)
Expansion Chamber Volume	1.935in ²	15.66in ²
Body Material	Polycarbonate, Nylon, Polypropylene, Polyester, Polyurethane, Buna-N, PVC	

Drawings:

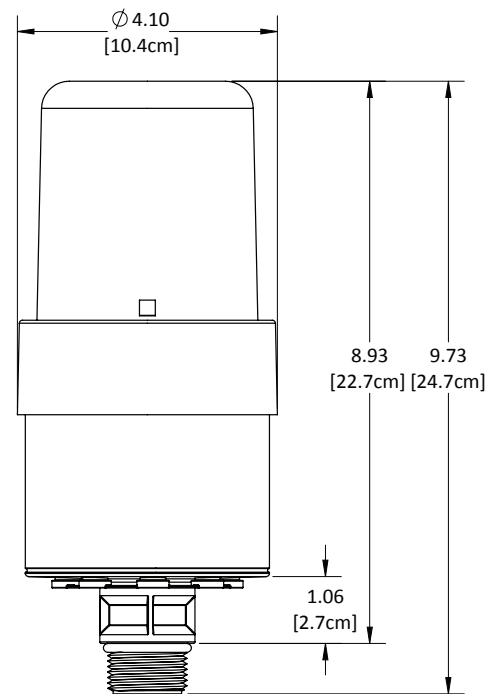
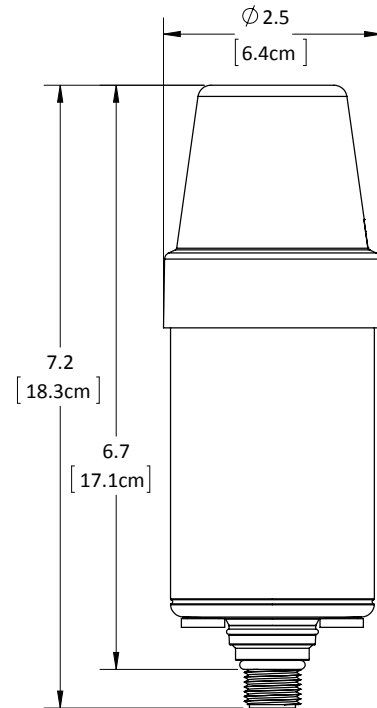

Did You Know?

HydroGuard breathers were specifically designed for steady-state operations with minimal temperature fluctuations. These breathers provide excellent protection in continuous duty applications. For check-valve protection in a variety of operating conditions, try a VentGuard instead.





Des-Case Corporation 675 N. Main St. Goodlettsville, TN 37072
P: 615.672.8800 F: 615.672.0701 descase.com
Filter Products
C O M P A N Y