

# FLUID HANDLING:

## TC Series Filter Cart

This heavy-duty, high capacity portable system is capable of removing particles and/or free water from all types of industrial oil and can be configured to meet the needs of almost any specific application.



# The Overview

## The TC Filter Cart:

### Where It's Used

- Decontaminating systems
- Flushing new or repaired systems
- Dispensing oil
- Pre-filtering new oil
- Evacuating used oil
- Topping off reservoirs
- Flushing systems
- Collecting oil samples for analysis

### What Can I Customize?

- Flow rates
- Sample valves
- Strainer type
- Color
- Power configurations
- Filter media types and sizes
- Type of power phase – single or three
- Manual bypass

### Product Features

#### Canisters:

Heavy-duty, industrial style with bolt-down lids and heavy gauge cylinder walls. These canisters can accept various size high-capacity microfiber glass, depth, water removal and molecular sieve elements and can be changed very easily.

#### Pump:

Continuous-duty gear pump; 1-40gpm flow rates available

#### Motor:

Washdown, heavy duty

#### Switch:

NEMA 4 industrial-duty

#### Frame:

Heavy-duty rectangular tubing

### Performance

#### Ambient Operating Temperatures:

- -25°F to 104°F (-32°C to 40°C)

#### Maximum Oil Temperatures:

- 175°F (79°C)

#### High Pressure Switch:

- Shuts down the system's motor at 65psi (5.49bar)

#### Pump Relief:

- Opens at 75psi (5.17bar) pump pressure

#### Materials:

- Frame: Carbon steel
- Paint: Industrial powder coat
- Fittings: Zinc-plated steel, brass, bronze, stainless steel, cast iron
- Pumps: Steel, Buna-N, iron, Viton®, graphite
- Hoses: EPDM or nitrile

#### Weight:

- Approximately 260-650lbs / 118 to 295Kg (will vary depending on system configurations)

#### Viscosity Range:

- ISO VG 2-680 at 100°F

#### Lifting Eye Bolts:

Allows for easy lifting and maneuverability

#### Hoses:

Steel braid reinforced hydraulic hoses

#### Gauges:

Pump pressure and differential pressure gauges

#### Strainer:

To protect the pump

#### Wheels:

16" solid rubber

#### Colors:

Standard is black; customizable colors available at no extra charge



# The Features

## By The Numbers

Item No.	Description	Qty.
1	Lifting Eye	1
2	First Filter Canister	1
3	Pressure Gauge	1
4	Sample Valve	1
5	High Pressure Switch	1
6	First Canister Differential Gauge	1
7	First Canister Drain	1
8	Second Canister Drain	1
9	Second Canister Differential Gauge	1
10	Outlet Hose	1
11	Inlet Hose	1
12	Second Filter Canister	1
13	Filter Canister Vent Valve	2
14	Inlet Strainer	1
15	Power Cord	1
16	Power Switch	1
17	Motor	1
18	Pump	1
19	Bypass Valve	1
20	Pump Relief Adjustment Screw	1

## Example of a Two-Canister System:

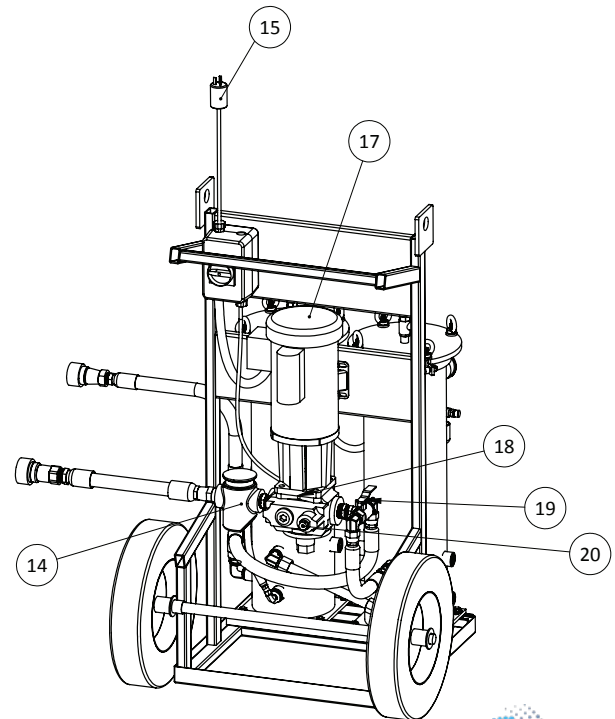
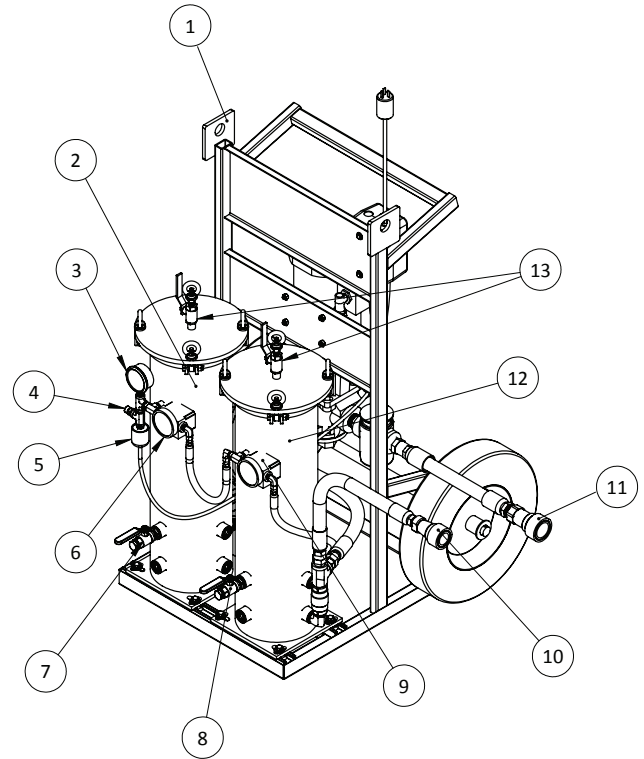

# FLUID HANDLING:

## The Entire Des-Case Line

We offer a full range of fluid handling and filtration products in Portable Filtration, Dedicated Filtration, Water Removal, Lubricant Storage & Filtration, Filter Elements, and Adapter Kits to suit your needs.

**Customize your system today at  
[www.descase.com](http://www.descase.com).**